

MOVE THE WORLD FORWARD MITSUBISHI
HEAVY
INDUSTRIES
GROUP

Q-ton *Air to Water*



 **MITSUBISHI HEAVY INDUSTRIES
AIR CONDITIONING EUROPE**

THE Q-TON STORY

A new generation, energy-efficient, sanitary hot water solution for commercial applications

The highly efficient Q-ton is an air-to-water heat pump that uses CO₂ gas as a refrigerant and can be used in a variety of applications for the supply of sanitary hot water. Q-ton has been featured as the world's first two-stage compressor (combining both rotary **1** and scroll **2** technologies). It maintains high efficiency and significantly improves the performance of providing hot water at cold outside air temperatures.

Mitsubishi Heavy Industries design team launched this innovative unique air source heat pump to allow maximum efficiency, with a minimal carbon footprint. This is all controlled from a comprehensive and easy to use touch screen panel. With the increasing pressure of the use of low GWP (Global Warming Potential) refrigerant, we believe our CO₂ heat pump is the way forward to comply with future regulations as well as current market trends.

Q-ton meets a range of demands including the need for medium to large sanitary hot water generation. This involves low electricity consumption and a high level of environmental friendliness.

TWO STAGE COMPRESSOR

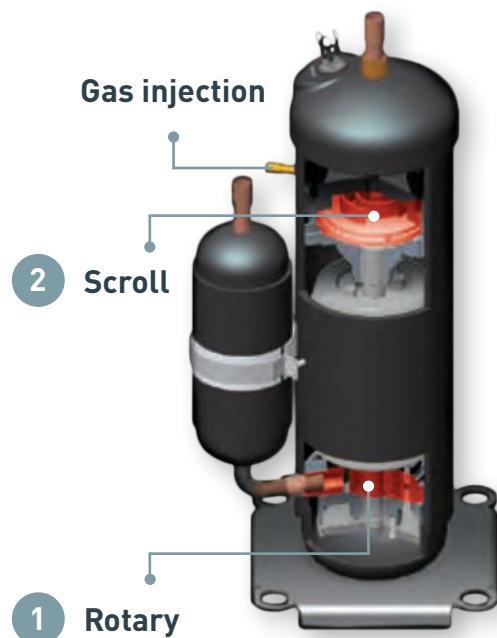

The combination of the two stage compressor demonstrates significantly improved performance from low to high ambient temperatures.

Gas injection into the medium pressure chamber increases the heating capacity.

To improve energy and carbon reduction performances, it is necessary to manage both the heat source as well as the heat storage capacity. Q-ton assures this is compatible with on-site hot water requirements.

For example a single remote panel can control a unit with the heating capacity of 30kW, but also can be utilized on up to 16 coupled units (a total of 480kW) for better functionality.

This enables the Q-ton to be specified in a vast array of new build or retrofit applications of all sizes.

With an industry-beating coefficient of performance (COP) of 4.3, it is the ideal system for serving hot water requirements in commercial buildings like hotels, apartment blocks, restaurants, fitness centres, universities, hospitals, care homes, laundries and food industries.

Systems can be programmed to meet specific requirements and a touch screen controller makes the system simple to operate whilst it's user-friendly graphic display enables to monitor hot water production and availability.

Typical Usage (Litres per day)

Leisure Centres
& Restaurants

3,000L

Care Homes
& Universities

5,000L

Hotels
& Spas

10,000L

Apartment
Blocks

15,000L



WHY Q-TON?

Q-ton delivers outstanding performance and environmental benefits to a varied number of applications and is exceptionally energy efficient, resulting in big reductions to both power and carbon emissions.

Q-ton uses the safe and highly efficient CO₂ as a refrigerant, which is environmentally friendly as it is a natural gas and does not contain harmful

ecological impacts compared to other products using standard refrigerants.

Furthermore, the Q-ton provides a constant hot water supply from 60°C to 90°C and maintains full capacity at a low ambient temperature, therefore having the additional benefit of no requirement for an external heating source resulting in reduced installation time and costs.

COMPARISON TO OTHER HOT WATER TECHNOLOGIES

Annual running cost (£GBP)

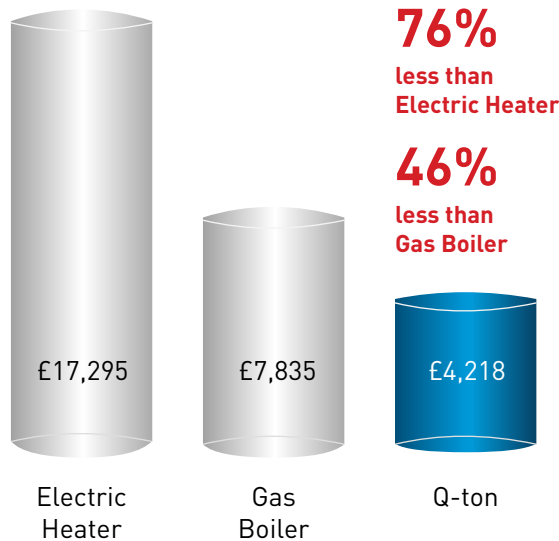

Annual CO₂ emission

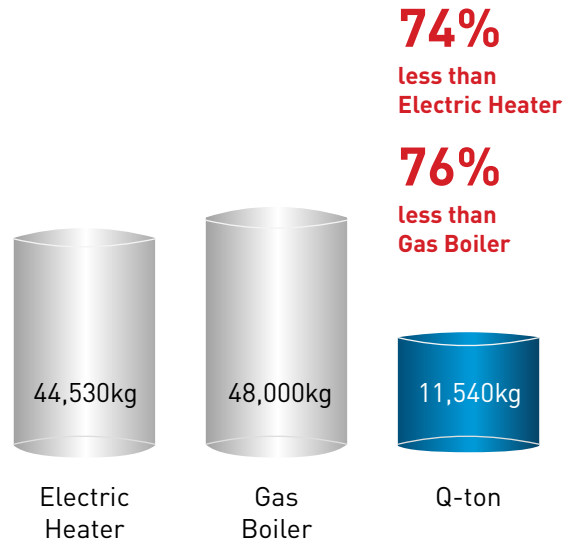

Q-ton reduces carbon emissions for any organisation and further savings are expected as the electricity becomes greener with the decarbonisation of the grid.

Q-TON BENEFITS

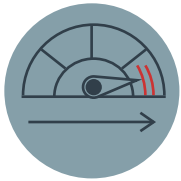

HIGH PERFORMANCE

- From 60°C to 90°C water supply even with outside temperatures as low as -25°C
- The ability to maintain 100% heating capacity down to -7°C



HIGH EFFICIENCY

- The industry's highest coefficient of performance (4.3 in intermediate season)*
- Massive reductions in both running costs and CO2 emissions

** Intermediate season conditions: Air on at 16°C, Water on at 17°C, Water off at 65°C*



ENVIRONMENTALLY RESPONSIBLE

- GWP (Global Warming Potential) = 1
- ODP (Ozone Depletion Potential) = 0



EASY OPERATION

- Advanced, but simple to operate touch screen panel with LCD
- User-friendly schedule setting and one-touch fill up operation



LONG-TERM RELIABILITY

- High quality robust technology
- Long life expectancy



MODBUS **NEW**

- Ability to send messages via Modbus communication
- Connection is possible with RCI-MDQE interface kit

We've always been solution focused



EASY TO USE CONTROLLER

- Advanced touch screen remote controller panel
- Full dot liquid crystal display
- Allows finely adjusted operation for energy savings

Clear Information

- Large panel with a light tap operation introduced as the industry's first.
- Large 3.8 inch full dot display.
- Back light function (for clear visibility).

Fill Up Operation

- Regardless of the programmed setting, there is always the option and functionality to manually refill the tank if demand is high.

Schedule Setting

- Set a schedule such as a weekly operation pattern, day off or a peak-cut timer.
- Possibility of setting 2 own operation patterns (User setting 1 & 2). **NEW**
- Possibility of setting hot water temperature settings on weekly schedule. **NEW**

Summer Time

- System automatically adjusts to daylight saving times allowing hassle free programming.
- Function can be enabled/disabled from the controller **NEW**

Environmental Credentials

Q-ton heat pumps can be configured as stand-alone units or run with up to 16 units connected, providing anything from 3,000 to 100,000 litres of safe hot water daily. Whether single or multiple units are used, the Q-ton system is controlled from a single, simple control panel that can be installed for ease of access and operation. Q-ton can be installed as a replacement to traditional hot water systems, additionally to existing systems or as a whole new system, according to your project needs.

Refrigerants such as carbon dioxide (R744) preserves the ozone layer (ODP = 0) and has the lowest Global Warming Potential (GWP = 1). Q-ton is an ideal fit for the latest building regulations contributing and reaching an “excellent” mark from BREEAM.

Q-ton helps to meet the stringent requirements of world’s foremost environmental assessment method and rating system BREEAM.

Q-ton Sizing Guidance

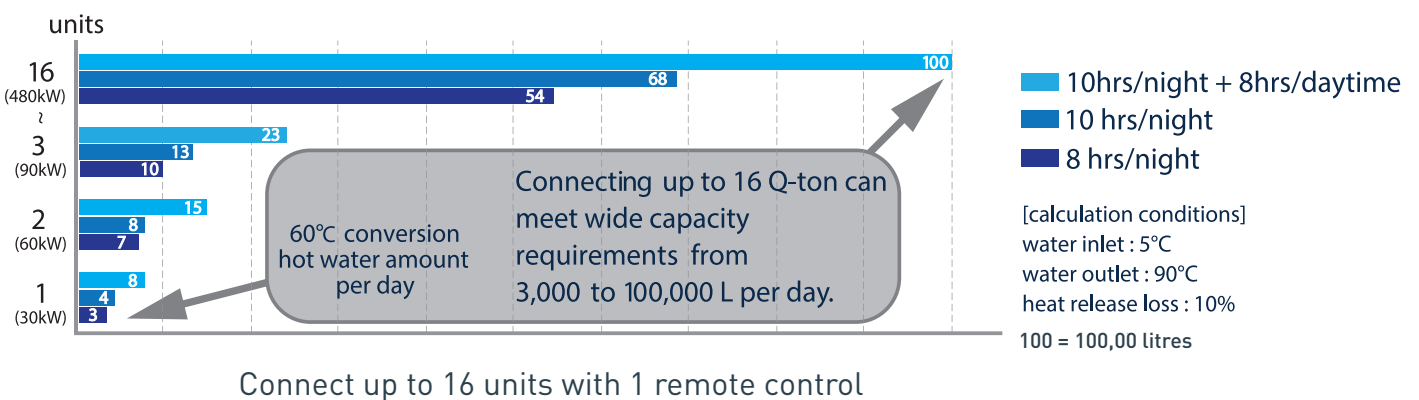

HOW Q-TON WORKS

The Q-ton heat pump absorbs 'free' heat from the outdoor air and amplifies it to generate hot water swiftly and efficiently and it can generate hot water up to 90°C without the requirement for an additional electric immersion heater. The Q-ton heat pump uses a coil of cold refrigerant that

absorbs 'free' heat from the outside air and using its unique 2-stage compressor puts the refrigerant under high pressure in order to raise its temperature. An onboard heat exchanger then uses heat from the refrigerant to generate the hot sanitary water.

PERFORMANCE
-25°C → 90°C
 90°C water supply even in extremely cold regions with temps as low as -25°C

CAPACITY
-7°C → 100
 Keeping 100% capacity down to -7°C

EFFICIENCY
COP 4.3
 The industry's highest COP level
 COP4.3 (intermediate season)

OUTLINE OF SYSTEM

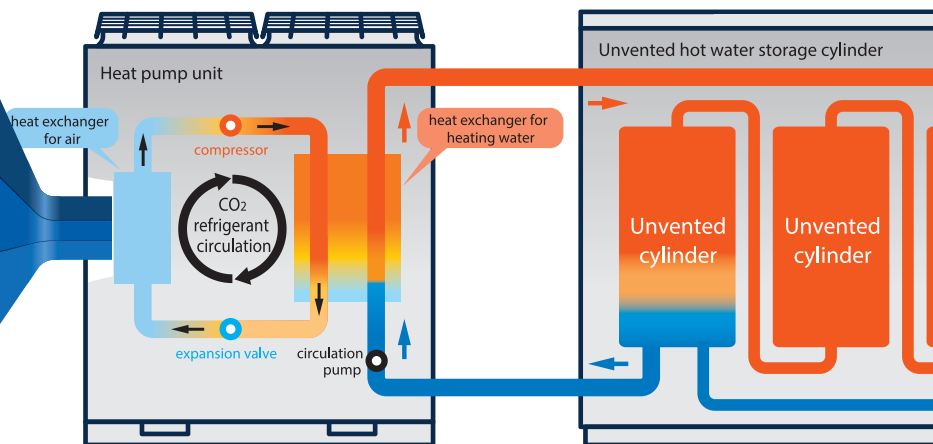

Each storage vessel has five pockets into which temperature sensors can be fitted to detect the volume (in % terms) of hot water held in the vessel at any particular time. The programming of the control

system to hold specific volumes of hot water at different times of day is based on a balance of hot water demand and electricity tariffs, this ensures hot water supply is maximised at a minimum cost.

Q-ton is usually used for direct boiler replacement as it controls the water supply and storage temperature as well as the output capacity.

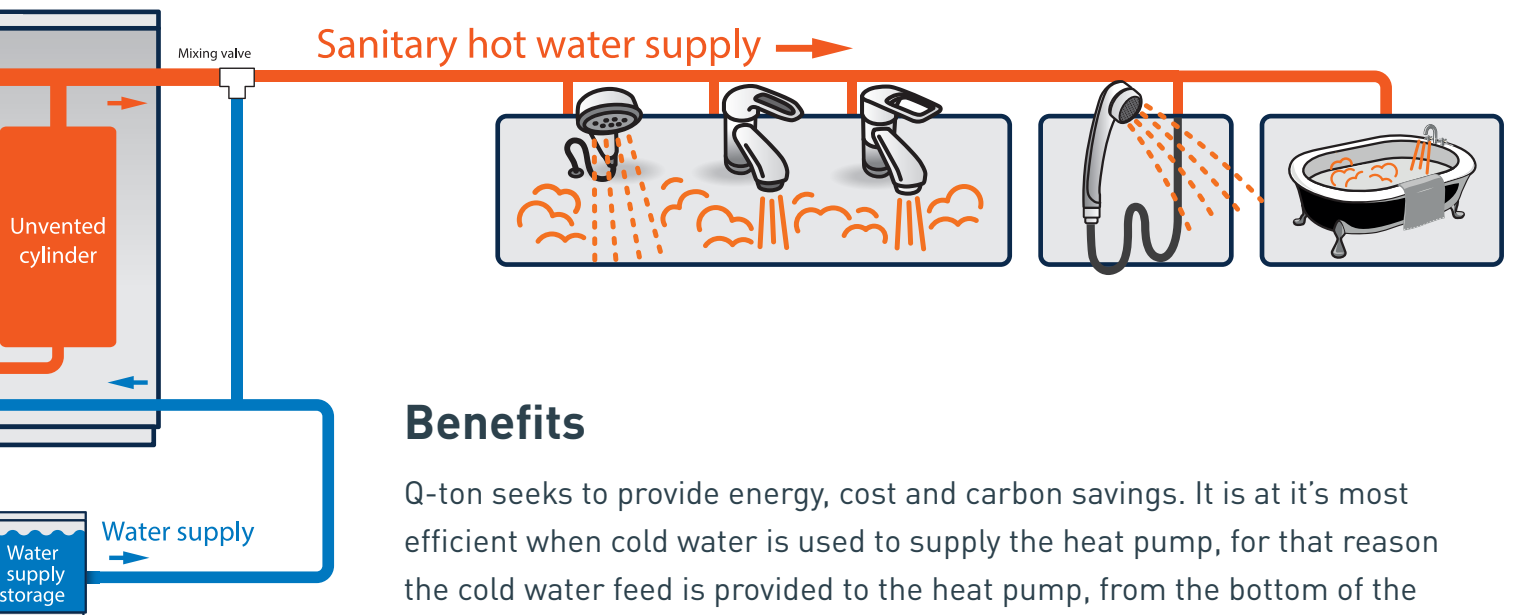

Benefits

Q-ton seeks to provide energy, cost and carbon savings. It is at its most efficient when cold water is used to supply the heat pump, for that reason the cold water feed is provided to the heat pump, from the bottom of the stratified storage vessel.

Hot water can be produced during the off peak electricity tariff which is then stored in a tank for daytime use. Q-ton efficiently produces high-volume hot water using ambient air and a small amount of electricity.

SPACE HEATING

NEW

In addition to the conventional hot water supply system, the space heating application has now been introduced in our CO₂ air to water heat pump.



Space Heating

For space heating applications with return temperatures below 30 °C

Examples of application:

- Underfloor heating
- Low temperature radiators

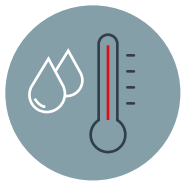

Combined Mode

In combined mode, heating with hot water supply is allowed at the same time.

Additionally it is possible to set the operation priority (Hot water or space heating)

PERFORMANCE

Operation down to
-25°C

CAPACITY

-7°C → 100%

Keeping 100% capacity down to -7°C

EFFICIENCY

146%

Average climate conditions

OUTLINE OF SYSTEM (SPACE HEATING)

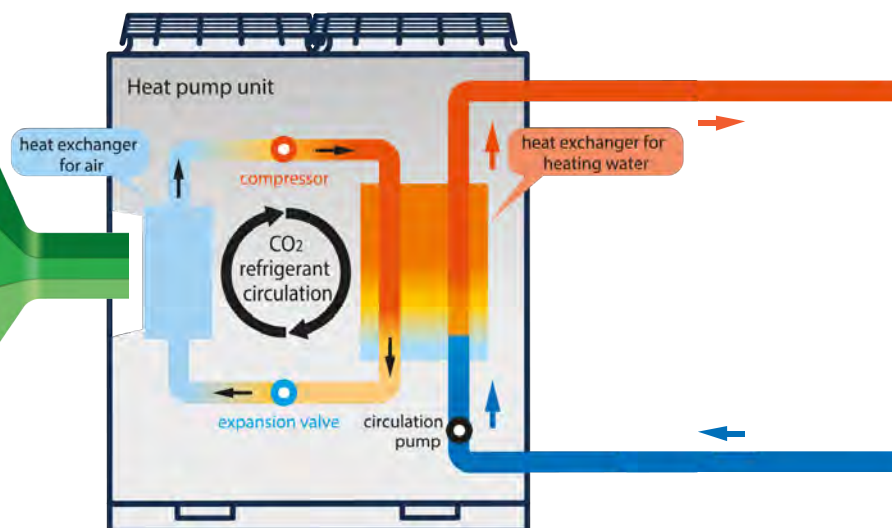

New Remote Controller (RC-Q1EH)

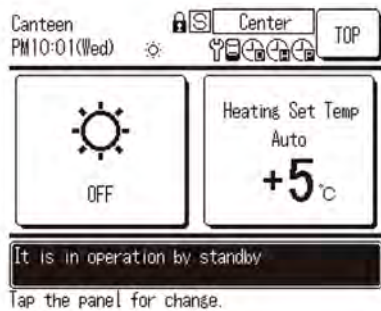
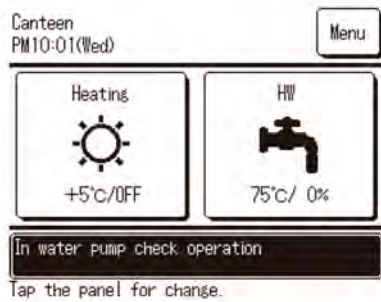

OPERATING MODES

We have upgraded our touch screen controller with heating and hot water setting operations.

When using space heating application it is possible to set two types of operation control:

1. Auto setting - Temperature is set according to the preset heating curve. Heating curve can be shifted up and down by 5 °C

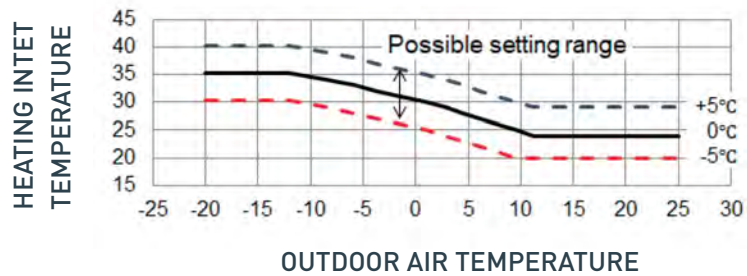

2. Manual setting - Target inlet temperature can be set manually from 20 °C to 52 °C

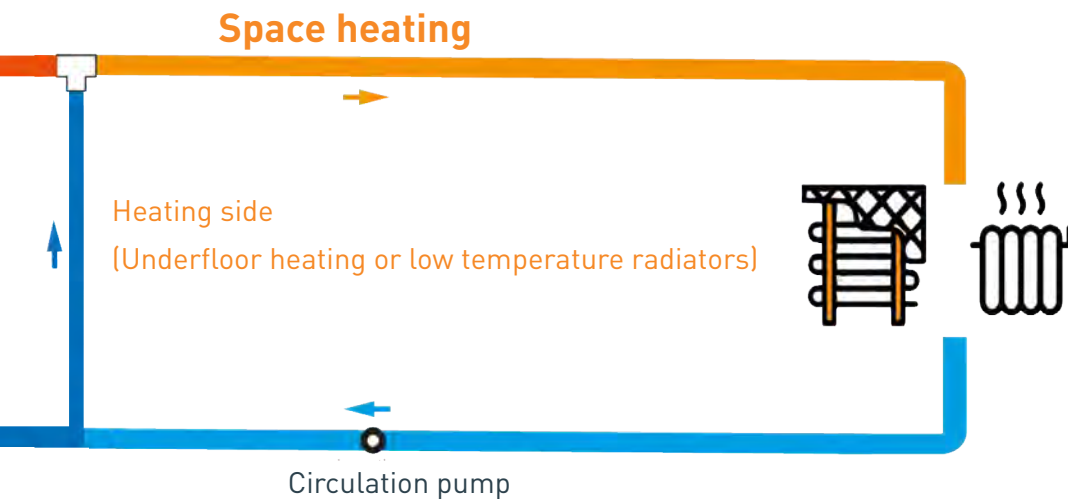

Benefits

Q-ton provides efficient and clean space heating with low GWP (1) natural refrigerant (R744)

Thanks to the use of a natural refrigerant it becomes cleaner than any traditional type heat pump refrigerant such as R410A or R407C.

Its flexibility allows for it to be installed in many heating applications and its efficient as a replacement to traditional gas and oil boilers.

SPECIFICATION

Model			ESA30EH-25
Power source		-	3 phase 380V +- 5%, 400V +- 5%, 415V +- 5%, 50/60 Hz
Operation to top up (In intermediate season)*1	Heating capacity	kW	30.0
	Water amount	L/min	8.97
	Power consumption	kW	6.98
	COP	-	4.30
Operation to top up (In cold season)*2	Heating capacity	kW	30.0
	Water amount	L/min	5.06
	Power consumption	kW	10.73
	COP	-	2.80
Operating sound pressure (In intermediate season)*1,3		dB(A)	58
Operating sound power (In intermediate season)*1		dB(A)	70
Exterior dimensions	Height	mm	1690
	Width	mm	1350
	Depth	mm	720 + 35 (Water pipe connection)
Current	Max.	A	21
	Starting	A	5
Unit weight		kg	375 (During operation 385)
Color			Stucco White (4.2 Y 7.5/1.1 approx.)
Compressor	Type x Pcs		Hermetic inverter compressor x 1
	Nominal output	kW	6.40
Refrigerant	Type		R744 (CO2)
	Charged amount	kg	8.5
Refrigerant oil	Type		MA68
	Charged volume	cc	1200
Crankcase heater		W	20
Anti-freezing heater	For water pipe	W	21x3
	For drain pan	W	40x2
	For drain hose	W	16x3
Heat exchanger, air side			Cooper pipe straight fin type
Heat exchanger, water side (gas cooler)	Type		Cooper pipe coil, indirect heat exchanger
	Possession quality of water	kg	10
Fan	Type		Axial flow type (direct coupled motor)x2
	Output x Pcs	W	386x2
	Air volume	m3/min	260
	External static pressure	Pa	50
Water pump	Type x Output		Non self suction spiral type inverter pump x 100W
	Materials contacting to water		PPS
	Actual pump head	m (kPa)	5m(49kPa) @17L/min
Usage temperature range	Outdoor air temperature	°C	-25 to 43
	Feed water inlet temperature	°C	Top up 5-35, Warm up 35-63
	Hot water outlet temperature	°C	60-90

Water pressure range		kPa	500 or lower (Keep water pressure more than 0kPa at the inlet of heat pump water heater)
Defrost			Hot gas type
Vibration and sound proofing devices			Compressor placed on anti vibration rubber and wrapped with sound insulation
Protection devices			High pressure switch, over current protection, power transistor overheat protection and anomalous high pressure protection
Pipe connection	Feed water inlet		Rc3/4 (Cooper 20A)*4
	Hot water outlet		Rc3/4 (Cooper 20A)*4
	Drain water outlet		Rc3/4 (Cooper 20A)*4
Electric wiring	Earth leakage breaker		30A, 30mA, 0.1 sec
	Power cable size		8mm2 x 4 (Lenght 70m)
	Molded-case circuit breaker		Rated current 30A, switch capacity 30A
	Grounding wire size		M6
	Remote control wire size		0.3mm2 x 2 cores shielding wire (MVVS)
Design pressure	MPa		High pressure -14 / Low pressure - 8.5
IP code			IP24

Note

- Performance of operation to top up in intermediate season shows the capacity measured under the conditions that outdoor air temp is 16 °C DB/12 °C WB, water inlet temp is 17 °C and hot water outlet temp is 65 °C.
- Performance of operation to top up in cold region shows the capacity measured under the conditions that outdoor air temp is -7 °C DB/-8 °C WB, water inlet temp is 5 °C and hot water outlet temp is 90 °C excluding heater for anti-freezing water (345W).
- Operating sound shows a value measured at 1m in front of the unit and 1m above the floor in anechoic room where the sound is resonated a little. Accordingly if the unit is installed on actual site, it is normal that the measured sound there is higher than the value shown above, because it is influenced by surrounding noise and echo in the room.
- The actual hot water outlet temp may vary ± 3 °C from target temp according to the change of outdoor air temp and water inlet temp. And then if feed water inlet temp is 30 °C or higher and outdoor air temp is 25 °C or higher, hot water outlet temp may be controlled not to increase too high.
- Please use clean water. The water quality should follow a guideline of JRA-GL. 02:1994.
If the water quality is out of the standard, it may cause troubles such as scale buildup and/or corrosion.
- These articles mentioned above may vary without any notice according to the development status.

Heating energy efficiency

Model		ESA30EH-25
Water heater load profile		XXL
Seasonal space heating energy efficiency class		A+
Water heating energy efficiency class		A
Annual energy consumption for space heating	Average	14822 kWh
	Warmer	9199 kWh
	Colder	15499 kWh
Annual energy consumption for water heating	Average	1909 kWh
	Warmer	1683 kWh
	Colder	3467 kWh
Seasonal space heating energy efficiency	Average	146%
	Warmer	174%
	Colder.	127%
Water heating energy efficiency	Average	114%
	Warmer	130%
	Colder	63%

DIMENSIONS

Model ESA30EH-25

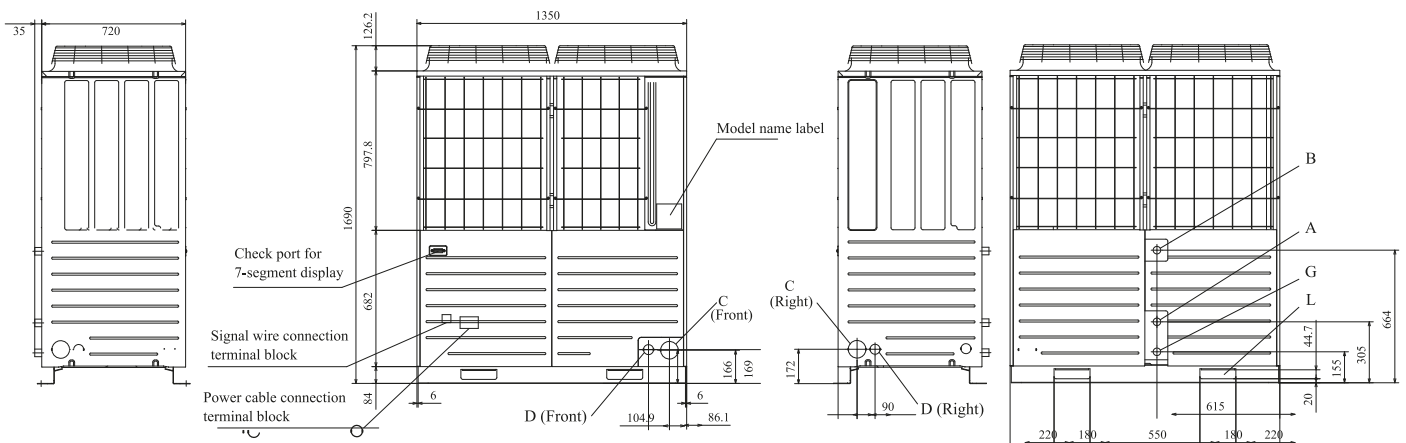

Symbol	Contents	
A	Feed water inlet port	RC3/4 (Cooper tube 20A)
B	Hot water outlet port	RC3/4 (Cooper tube 20A)
C	Heat pump unit - Tank unit connecting wire outlet port	88 mm diam. (or 100 mm diam.)
D	Power cable inlet port	50 mm diam. (right, front) Long hole 40 x 80 (bottom)
G	Drain water pipe outlet port	RC3/4 (Cooper tube 20A)
L	Hole for carrying or hanging	230 x 60

Installation space (Service space)

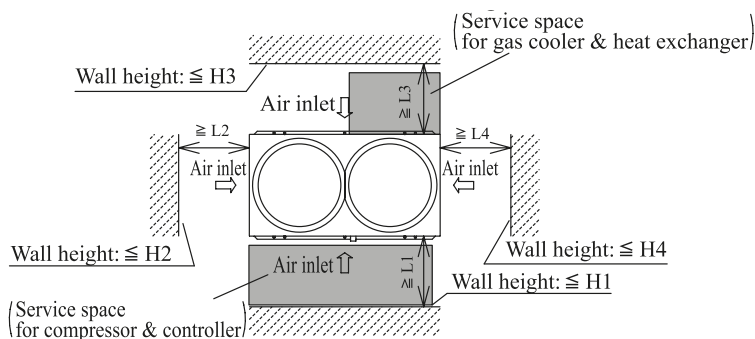

Dimension/Installation example	I	II
L1	800	800
L2	10	10
L3	800	500
L4	100 (*)	500
H1	1500	1500
H2	Not limited	Not limited
H3	1000	1000
H4	Not limited	Not limited

Note

1. Be sure to fix the unit with anchor bolts
2. Be sure to keep space above the unit at least 2m
3. The connection of water pipes (Feed water inlet, Hot water outlet, Drain water outlet) should be done on site locally.
4. The holes for power cable inlet, and connection wire outlet from heat pump unit to tank unit are half-blanked. Therefore please punch out the hole by cutting the residual portion and use it.
5. In heavy snow region, please take following measures in order for the air inlet/outlet port and the bottom part of unit not to be covered with snow
 1. Place unit on the rack in order to make the bottom of the unit higher than the snow surface.
 2. Install a snow prevention hood on the outlet port of the unit.
 3. Install the unit at the space under the eaves or the snow prevention roof.
6. If ambient temp becomes below 0 °C, it may cause break of water pipes and damage on the unit due to freezing. Be sure to apply anti-freezing heater to feed water piping, a hot water piping and drain water piping in order to prevent from freezing.
7. Be sure to keep enough service spaces of more than 800mm in front of the unit service panel for easy inspection of the unit and replacement of components. When piping work is done, be sure not to interfere the pipes with the unit service space. If the service space cannot be kept, please install the piping below the unit by placing the unit on the rack.

WE'VE ALWAYS BEEN SOLUTION FOCUSED

For our customers it's comforting to know that we always listen to their needs when developing our products. As an engineering company built on problem solving, we understand that not every requirement has a ready-made answer.

Mitsubishi Heavy Industries Air Conditioning Europe Ltd (MHIAE) is a company created by MHI for all HVAC solutions across Europe. MHIAE offers high-efficiency systems for cooling and heating of both air and water in residential, commercial and industrial applications. As a reputable engineering company with vast expertise and experience, we are fully equipped to meet all your HVAC needs.

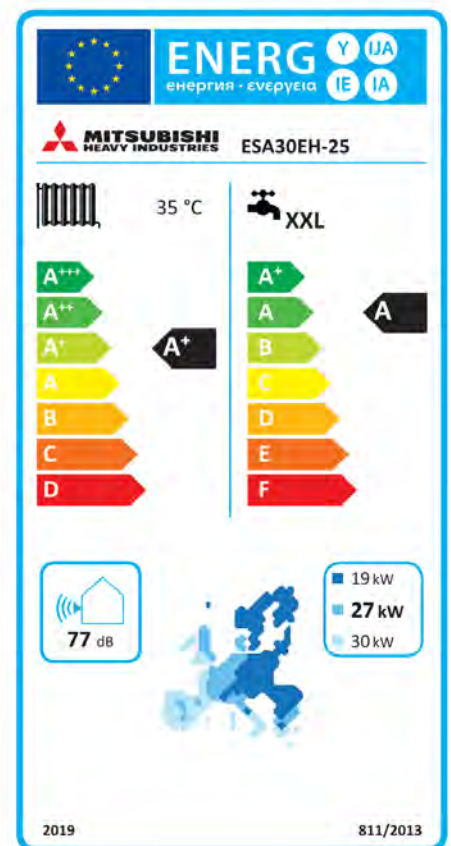

Cert No: MCS HP0230 Technology: Heat Pump



Mitsubishi Heavy Industries Air-Conditioning Europe, Ltd.

5 The Square, Stockley Park, Uxbridge, UB11 1ET

www.mhiae.com

ISO9001

Our Air Conditioning & Refrigeration Systems Headquarters is an ISO9001 approved factory for residential air conditioners and commercial-use air conditioners (including heat pumps).



BIWAJIMA PLANT
Mitsubishi Heavy Industries, Ltd.
Air-conditioning & Refrigeration Systems Headquarters
Certified ISO 9001
Certificate number : JGA-0709



MITSUBISHI HEAVY INDUSTRIES-MAHAJAK AIR CONDITIONERS CO., LTD.
Certified ISO 9001
Certificate Number : 04100 1998 0813



MITSUBISHI HEAVY INDUSTRIES-MAHAJAK AIR CONDITIONERS CO., LTD.
Certified ISO 14001
Certificate Number : 04104 1998 0813 ES

