



Sustainable **Cold Solutions**

CO₂ condensing unit



*Equipped with
water/brine cooled gas cooler*

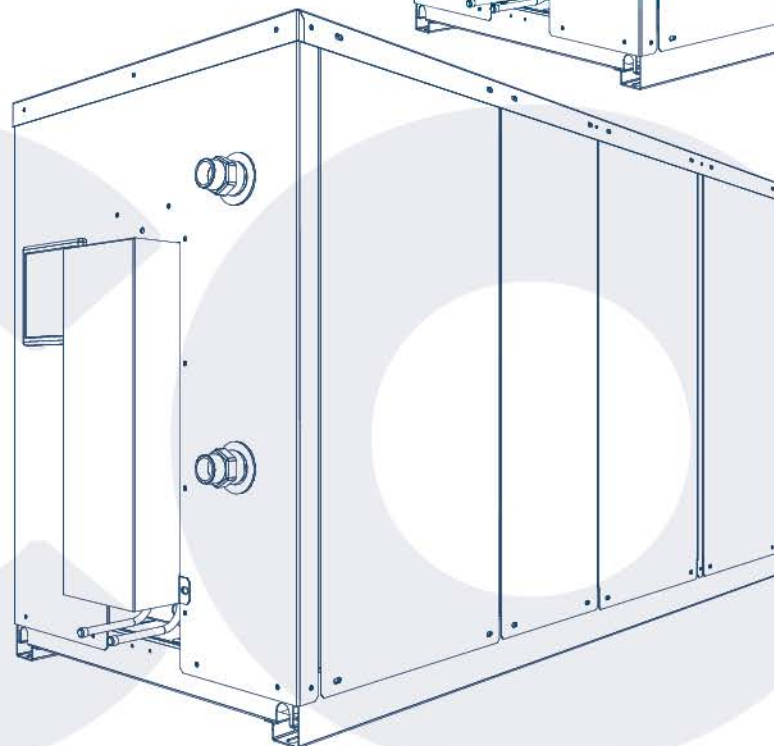
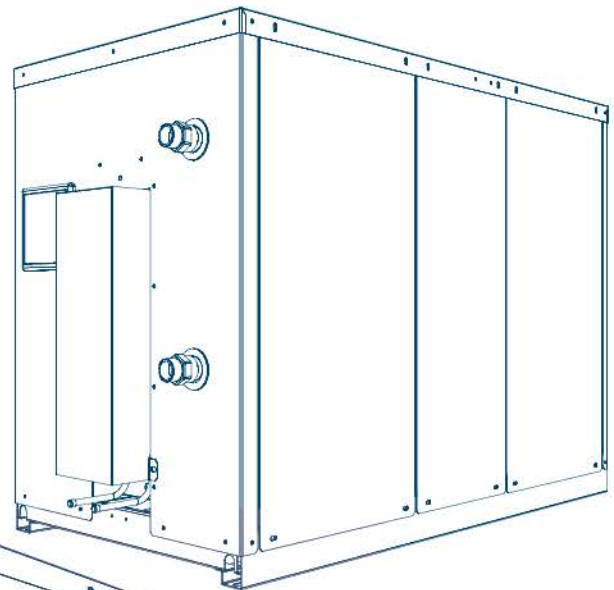

MANUFACTURED BY:
SCM REF AB

A **BEIJER REF** Company

Eng-Ita
Deu-Fra

According to SCM Natural Choice, we have developed a **range of CO₂ transcritical condensing units** with a very low carbon footprint and lower energy consumption than the traditional HFC solutions.

Design is compact and units are easy to install and maintain. Units are equipped with water/brine cooled gas cooler and electrical panel, tested and factory programmed for an easy start-up.

STANDARD CONFIGURATION

◇ *DC Brushless Rotary compressor*

◇ *Inverter modulation 25% - 100%*

◇ *BPHE gas cooler*

◇ *Small footprint*

◇ *K65 connections*

◇ *Design pressure:*

120 bar (high pressure side)

80 bar (liquid line)

80 bar (suction)

OPTION ON REQUEST

◇ *Liquid Receiver 8 liter on MT (PED II)*



Unità di refrigerazione a CO₂ per applicativi di Media e Bassa Temperatura

Sistemi transcritici ad espansione diretta

Modello UMT T MTDX. *Capacità frigorifera da 0,6 a 8,5 kW.*

Modello UMT T BTDX. *Capacità frigorifera da 0,65 a 6,6 kW.*

CO₂-Kälteanlage für die Anwendung im Mittleren und Tief- Verdampfungstemperaturbereich

Transcritisches System DX

Modell UMT T MTDX. *Kälteleistung von 0,6 bis 8,5 kW.*

Modell UMT T BTDX. *Kälteleistung von 0,65 bis 6,6 kW.*

CO₂ Systems for medium and low temperature applications

Transcritical condensing units DX

Model UMT T MTDX. *Cooling Capacity from 0,6 up to 8,5 kW.*

Model UMT T BTDX. *Cooling Capacity from 0,65 up to 6,6 kW.*

Groupes de condensation au CO₂ pour applications pour moyenne et basse température

Groupes de condensation transcritiques à détente directe

Modèle UMT T MTDX. *Puissance froid de 0,6 à 8,5 kW.*

Modèle UMT T BTDX. *Puissance froid de 0,65 à 6,6 kW.*

MEDIUM TEMPERATURE

Model MTDX	Performance with T Brine in +32°C	Tev (°C)					MRA A	Pmax W
		-15°C	-10°C	-5°C	0°C	5°C		
UMT WG T 030 MTDX	Qo (W)	2241	2641	3045	3482	3976	9,4	2115
	Pel (W)	1253	1262	1288	1302	1286		
	COP	1,79	2,09	2,36	2,67	3,09		
	MEPS	1,76						
	V / Ph / Hz	230 / 1+N+PE / 50						
UMT WG T 045 MTDX	Qo (W)	3402	3966	4624	5321	6084	13,9	3155
	Pel (W)	1872	1927	1922	1916	1886		
	COP	1,82	2,06	2,41	2,78	3,23		
	MEPS	1,76						
	V / Ph / Hz	230 / 1+N+PE / 50						
UMT WG T 067 MTDX	Qo (W)	4758	5615	6496	7489	8416	20,9	4765
	Pel (W)	2785	2840	2940	2956	3061		
	COP	1,71	1,98	2,21	2,53	2,75		
	MEPS	3,44						
	V / Ph / Hz	230 / 1+N+PE / 50						
UMT WG T 100 MTDX	Qo (W)	7101	8290	9624	11038	12347	15,1	7560
	Pel (W)	4157	4376	4486	4569	4847		
	COP	1,71	1,89	2,15	2,42	2,55		
	MEPS	3,45						
	V / Ph / Hz	400 / 3+N+PE / 50						

MTDX - Inverter modulation from 25 to 100% (1500 → 6000 rpm)

Dimensions: mm 1150x570x805

Weight: kg 150

Refrigeration connections: Suction inch 3/8" (exc. UMTT 100: 1/2") | Liquid inch 3/8"

Water/brine connections: 1" ISO228

Sound Pressure: dB(A) 41 (based on freefield area with semi-spherical sound emission in 10 m distance)

LOW TEMPERATURE

Model BTDX	Performance with T Brine in +32°C	Tev (°C)			MRA A	Pmax W
		-30°C	-25°C	-20°C		
UMT WG T 030 BTDX	Qo (W)	3343	3662	3904	13,9	3190
	Pel (W)	2147	2149	2153		
	COP	1,56	1,70	1,81		
	MEPS	2,3				
	V / Ph / Hz	230 / 1+N+PE / 50				
UMT WG T 045 BTDX	Qo (W)	5049	5331	5700	20,7	4760
	Pel (W)	3242	3250	3242		
	COP	1,56	1,64	1,76		
	MEPS	2,3				
	V / Ph / Hz	230 / 1+N+PE / 50				
UMT WG T 067 BTDX	Qo (W)	6599	7268	7797	20,4	7065
	Pel (W)	4902	4994	5097		
	COP	1,35	1,46	1,53		
	MEPS	2,24				
	V / Ph / Hz	400 / 3+N+PE / 50				

BTDX - Inverter modulation from 25 to 100% (1500 → 6000 rpm)

Dimensions: mm 1545x570x805

PED: // Liquid receiver 8 liter

Weight: kg 176

Refrigeration connection: Suction inch 3/8" | Liquid inch 3/8"

Water/brine connections: 1" ISO228

Sound Pressure: dB(A) 41 (based on freefield area with semi-spherical sound emission in 10 m distance)

CO₂ RANGE

A solution for all applications

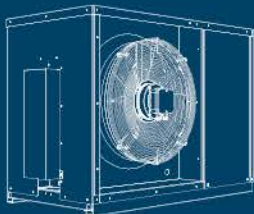

CUBO₂
SMART

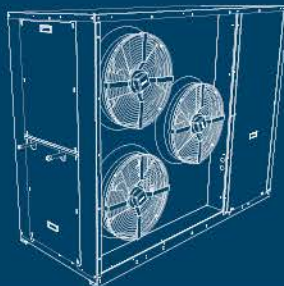

CUBO₂
PLUS

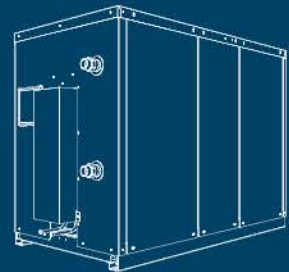

CUBO₂
AQUA

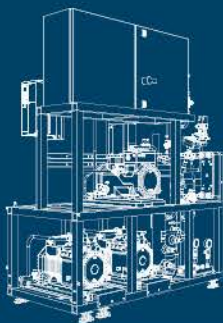

SMART
BOOSTER

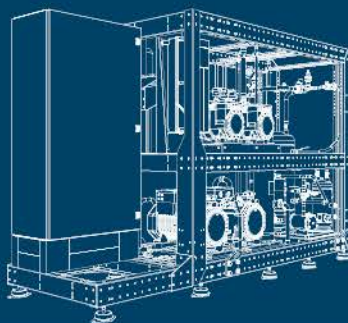

LEAN
BOOSTER

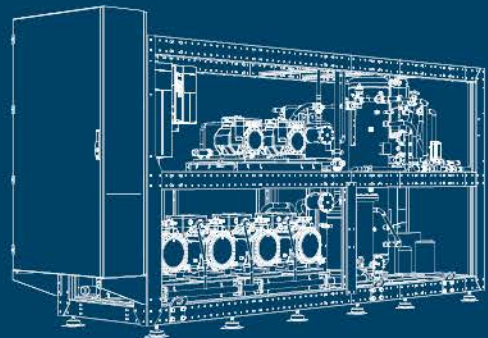

BOOSTER SMKT

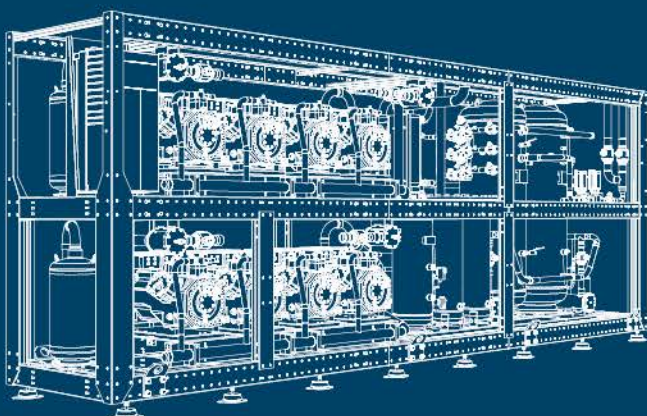

BOOSTER INDUSTRIAL

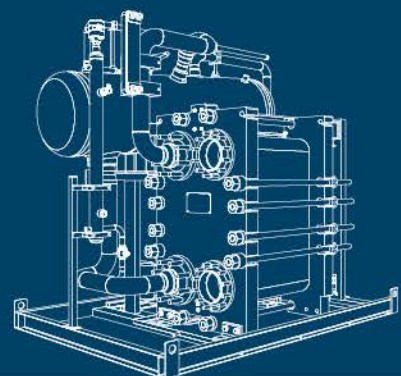

CHILLER

